

[CR is directed to contact on: danishrafiq32@gmail.com/abid@nitsri.net]

1. Obtain the transfer function models for the following circuits:

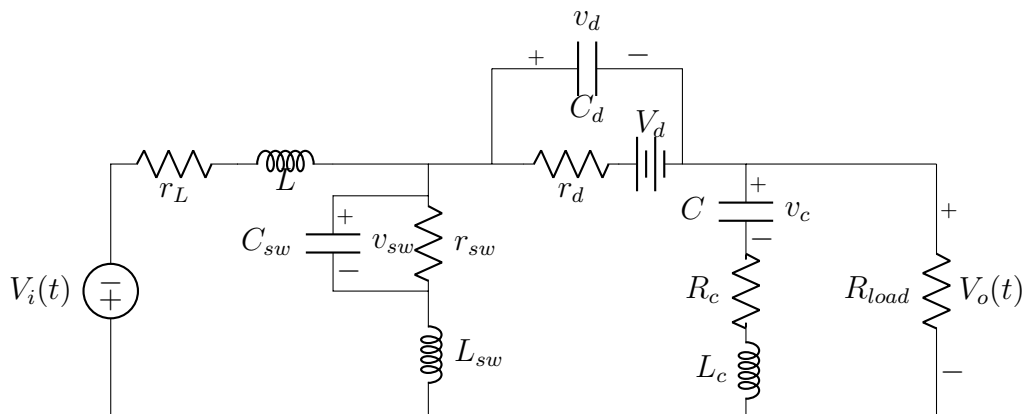
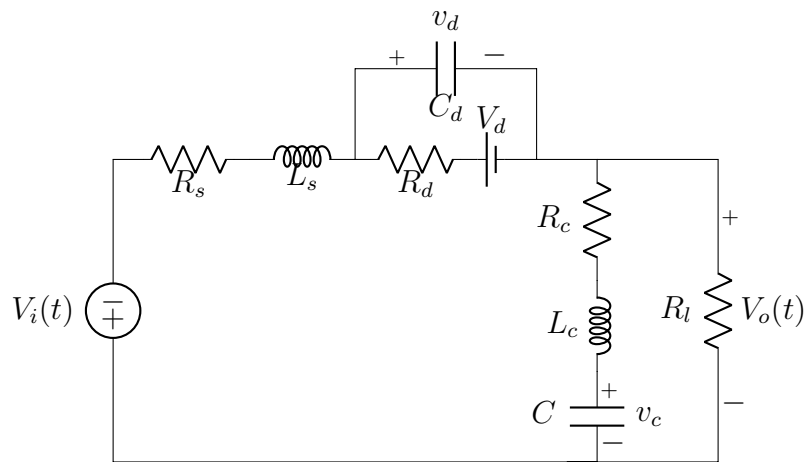
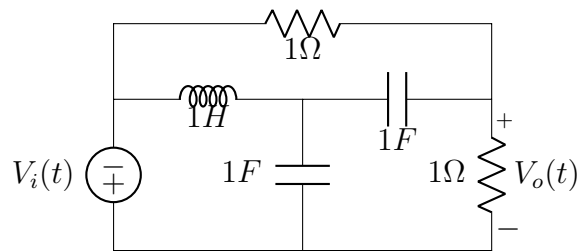
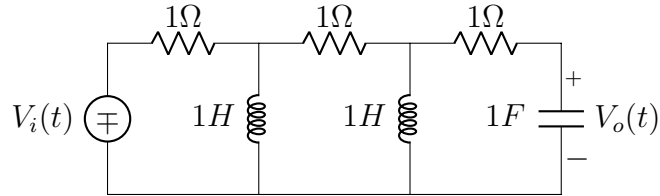

2. A system is described by the following differential equation

$$\frac{d^3y}{dt^3} + 3\frac{d^2y}{dt^2} + 5\frac{dy}{dt} + y = \frac{d^3x}{dt^3} + 4\frac{d^2x}{dt^2} + 6\frac{dx}{dt} + 8x$$

Find the expression for the transfer function of the system, $Y(s)/X(s)$

3. Write the differential equation for the system with transfer function

$$G(s) = \frac{s^5 + 2s^4 + 4s^3 + s^2 + 4}{s^6 + 7s^5 + 3s^4 + 2s^3 + s^2 + 5}$$

4. Write the differential equation that is mathematically equivalent to the system with transfer function

$$G(s) = \frac{s^4 + 3s^3 + 2s^2 + s + 1}{s^5 + 4s^4 + 3s^3 + 2s^2 + 3s + 2}$$

with input $r(t) = 3t^3$.

5. Construct transfer function models for the following differential equations.

(a) $\ddot{y} + 3\dot{y} + 2y = \dot{u} + u$

(b) $\ddot{y} + 6\dot{y} + 11y = u$

(c) $\ddot{y} + 6\dot{y} + 11y = \ddot{u} + 8\dot{u} + 17u + 8u$